

## **An Overview of Recent Research and Development in Contamination Control Flooring**

Presented at: 22NS NORDIC R<sup>3</sup> SYMPOSIUM, JUNE 1991, ROVANIEMI, FINLAND

By: Catherine Allen BA Hons, MSEE  
Dycem Limited, Bristol, England

**A review of the current range of active contamination control mats and flooring and recent research comparing the working and effectiveness of two types of tacky flooring products. An introduction to a new instrument to measure the vertical tack of Dycem Contamination Control flooring.**

A review paper by Martin Hazlewood on the Design and Construction of Flooring in Gowning and Associated Areas categorizes cleanroom compatible flooring into functional, passive flooring and active contamination control flooring. Mr Hazlewood's paper provides an excellent overview of the types of flooring available and their basic advantages and disadvantages. And introduces tacky flooring under the heading of active, contamination flooring. This paper tackles the subject of tacky flooring in greater detail, looking more closely at the choice of products available and at recent research comparing these products.

There are two types of tacky contamination control flooring- the disposable, adhesive-coated sheets, which are only available as mats, and the washable, permanently tacky polymeric products which are available as both mats and as flooring.

Dycem Limited is the market leader in the washable tacky flooring and is the only company to offer both mats and flooring. Since introducing Protectamat, the first washable tacky mat, in the 1970's, Dycem has continued to research and develop new products. In 1985 Dycem developed static-dissipative, tacky flooring, and since then Dycem has added a range of low-profile mats which are available both in loose-laid and self-adhesive forms, and in neutral and static-dissipative versions.



*Dycem CleanZone*



*Dycem Low-Profile Protectamat*

Furthermore Dycem has instigated and funded the development of an instrument to measure the vertical tack of polymeric flooring.



*Dycem Tack Meter*

The Dycem Tack Meter imitates placing a foot on a tacky surface and lifting it off. The meter measures the force required to pull the imitation brass foot from the surface of the tacky flooring. The reading therefore quantifies the vertical tack of the flooring, and this reading directly correlates with the ability of the surface to collect and retain particulate. The metered is invaluable in terms of monitoring the ageing process of the tacky flooring in order to determine its efficiency and eventually the need to replace the product. Tack meters are available to all Dycem customers.

In accordance with its policy to improve and expand its products, Dycem has also funded independent research into the particle collecting efficiency of the Dycem Protectamat versus a standard peel-off mat. This research has been carried out by Mr W. Whyte of the University of Glasgow and is currently being written up for publication later this year. The test procedure involves imitating a contaminated shoe sole being on the dust-collecting mat. Two types of test were carried out to measure the particle-collecting efficiency firstly of a clean, 'fresh' area of mat, and secondly of an

area becoming increasingly contaminated through a number of footfalls.

The human footfall was imitated by a brass wheel to simulate as accurately as possible both the load bearing surface and the rolling motion of the average footfall.

#### Test Wheel

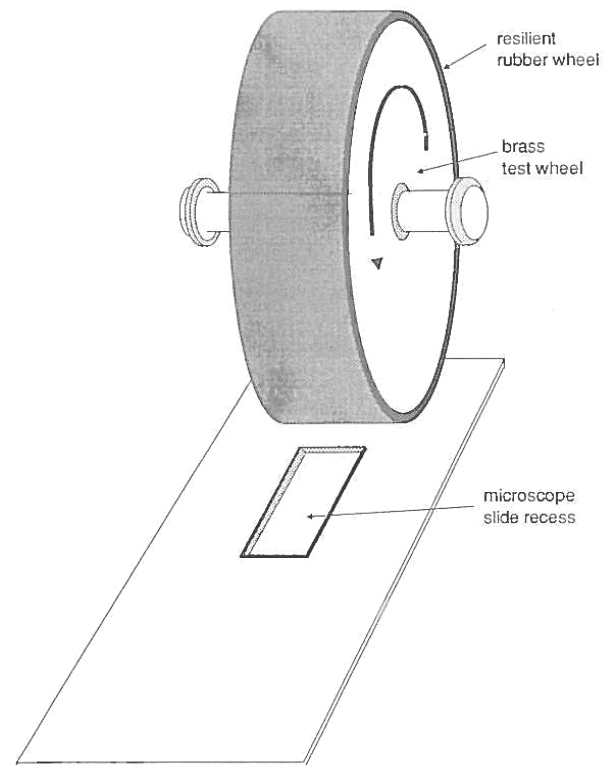

The contamination was provided by silica particles, a heterogeneous particle media with a ubiquitous nature and commonly present on footwear. All the tests involved depositing a known particle density onto a microscopic slide. During the tests the particles were counted using a special optical microscope, and on occasions the

slide were also weighed and the particles sized as well as counted.

For the first test a fresh piece of mat was rolled over a contaminated slide and then a further fresh piece of mat rolled over the same slide. This process was continued until there were insufficient particle to count. The preliminary results showed that by the third roll the particle count was practically zero. These results confirm that three footfalls are required to decontaminate a shoe sole. However, the results also lead to further conclusions. Firstly that, although the peel-off mat, by virtue of being coated with adhesive, feels tackier when fresh, it does not remove any particles. And, secondly, analysis of the numerous tests carried out with a variety of particle loadings, shows that as the particle load increased the efficiency of particle removal decreases but the Dycem polymeric mat remained consistently more effective.

For the second test a fresh piece of mat was rolled over a contaminated slide and then the exact same area of mat was rolled over a succession of contaminated slides: thus imitating a number of shoe soles treading on the same area of a mat.

As expected the efficiency of removal decreased as the particle contamination of the mat increased but the polymeric mat remained consistently more efficient. The lowest recorded efficiency of the Dycem mat being 57% as compared with 16% for the peel-off mat.

In any area where contamination control is a priority, the continued ability of flooring to collect particulate is of great importance. Tests have shown that the adhesive layer of a peel-off mat rapidly

becomes saturated. The reduced efficiency of the peel-off mat when contaminated means that the layers should be peeled of frequently, thus further increasing the cost of such mats. The smooth, compliant surface of Dycem products is more efficient and more cost effective than an adhesive layer on the flooring surface, and the extensive range of Dycem mats and flooring, allows the customer to choose a product to match his requirements.

***Efficiency of Protect mat with a progressively dirtier surface***

Wt of dust (mg/cm <sup>2</sup> )	0.50 % of particles removed	0.12 %	0.18 %	0.27 %	0.23%	Average 0.26 mg/cm <sup>2</sup> %
Slide 1	>90	>99	86	63	70	86
Slide 2	87	88	67	75	55	75
Slide 3	75	55	70	64	58	64
Slide 4	71	79	57	53	43	57
Slide 5	23	72	61	23	57	57

***Efficiency of peel-off mat with a progressively dirtier surface***

Wt of dust (mg/cm <sup>2</sup> )	0.50 % of particles removed	0.12 %	0.18 %	0.27 %	0.23%	Average 0.26 mg/cm <sup>2</sup> %
Slide 1	23	12	19	51	19	19
Slide 2	16	61	14	12	13	14
Slide 3	15	24	25	14	18	18
Slide 4	33	20	20	5	11	20
Slide 5	24	16	16	10	14	16

## References

1. Hazlewood, Martin, *"The Design and Construction of Flooring in Gowning and Associated Areas"*  
How Air Limited
2. *"The Basics of Cleanroom Design"* Pub. ICE Corp
3. *"Change Rooms, Design and Operation"*  
Stokes, K.H
4. Fitton, P and Barrett, Dr G.F.C, *"New Development in Contamination Control Flooring"*  
Pub. ICCCS, Milan 1986
5. Miller, D.P *"The Architectural Ergonomics and Sandias RHIC-II Gowning Facility"*
6. L.M. Hargreaves BSc, CChem, MRSC, MSEE. *" A Comparative Study of Dycem Protectamat and Peel-off Mats by Particle Counting Analysis"*, (Pub.ICCCS, Los Angeles 1988)
7. Whyte, W, *"Particle Removal Efficiency of Cleanroom Mats"* (Preliminary Report)  
Building Services Research Unit, University of Glasgow